

STONE

BY ADAMSEZ

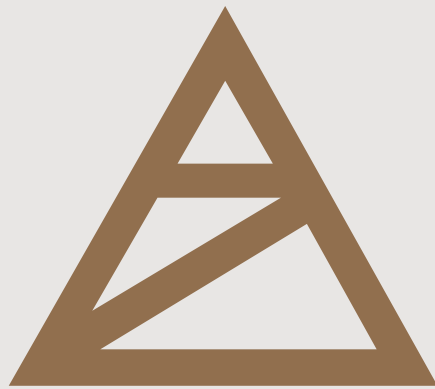

SINCE 1880



ADAMSEZ[®]

Luxury Bathroom Products

SINCE 1880

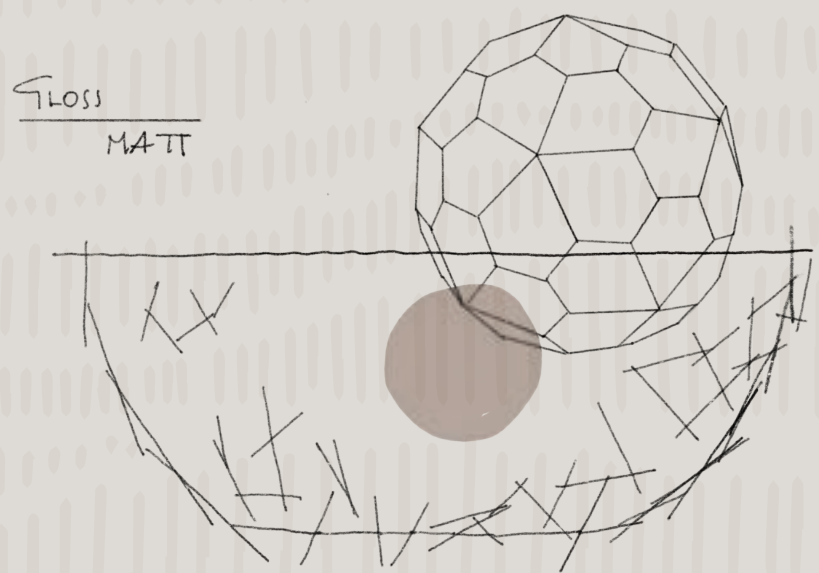
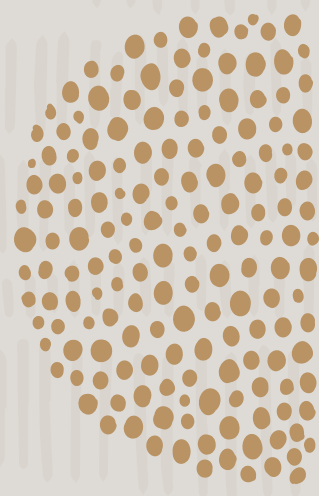
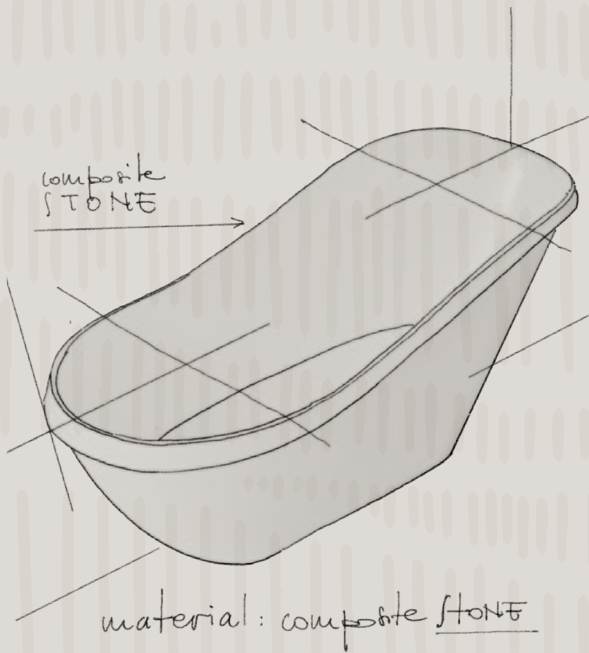

- STRENGTH
- ELEGANCE

Bathing
SPACE

function & style

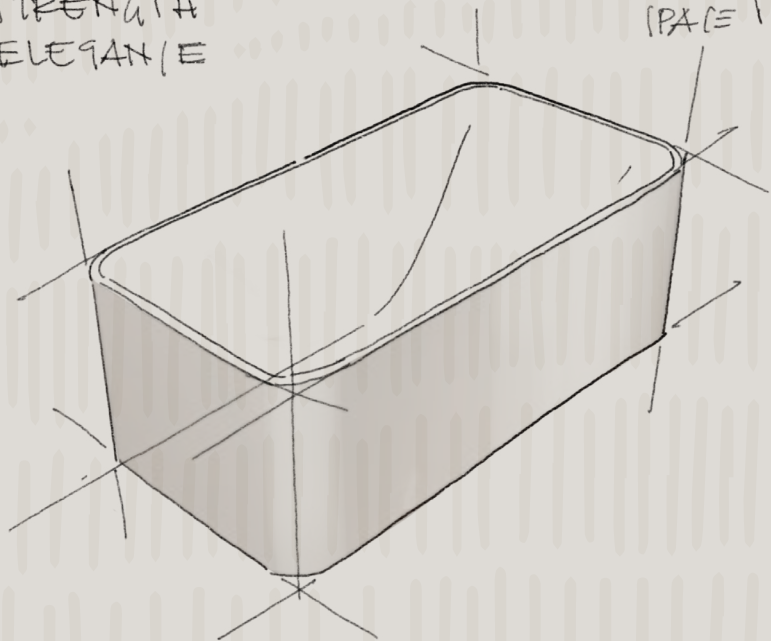

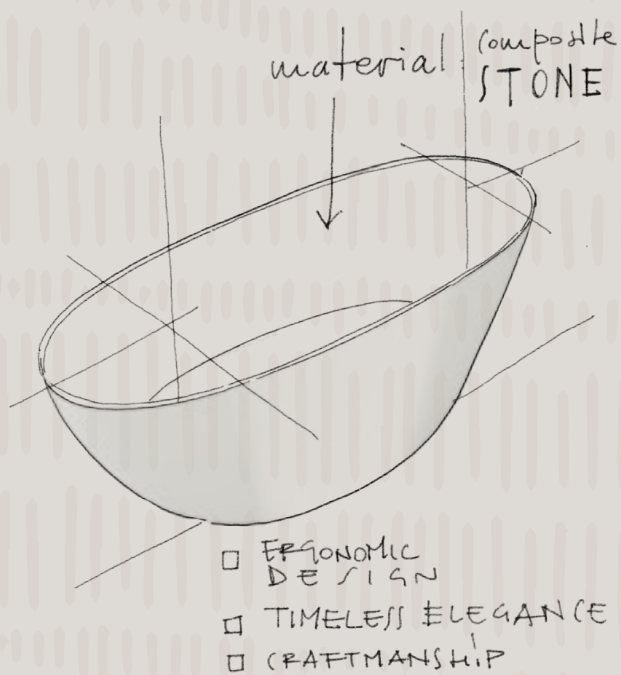

- ERGONOMIC DESIGN
- TIMELESS ELEGANCE
- CRAFTMANSHIP



THE

Stone by Adamsez

FREESTANDING BATH COLLECTION

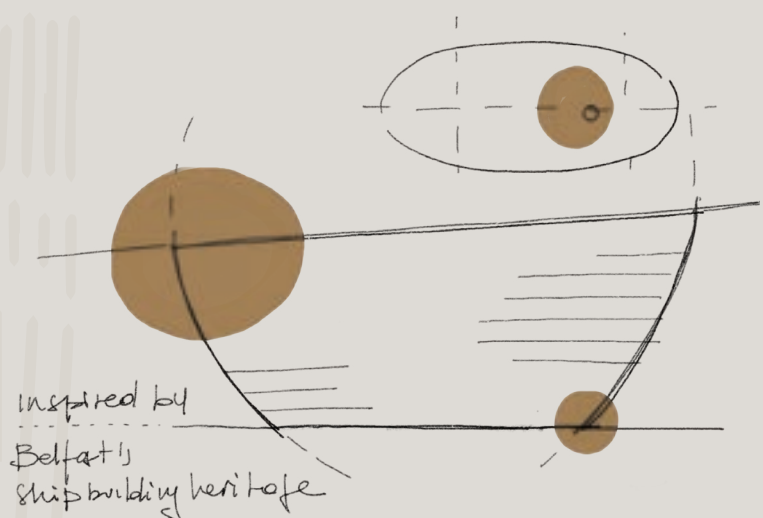

Inspired by
Belfast's
shipbuilding heritage

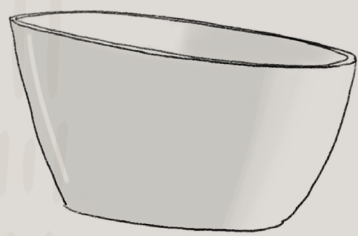



Harland - Page 14
Paired with Aqualla Avante brassware and recessed shelves in matt black.

Contents



AdCast Stone Freestanding Baths	10
Thompson	12
Harland	14
Lewis	16
Clarendon	18
Geo	20
Mila	22
Santo	24
Lincoln	26
York	28

AdCast Stone Wash Basins	31
Geo	34
Olympic II	34
Pebble	35
Gem	35
Sonata	36
Cara II	36
Orb	37
Plazza	37
Thompson	38
Rochester	38
Mila	39

AdCast Countertops	40
Optional Extras	42
AdColour	46
Our Journey	47
Aqualla Products	49
Our Sustainability Journey	50



Thompson Wash Basin with *Aqualla Hanna*
Brushed Bronze Wall Mounted Basin Mixer -
See Page 38.

Why choose Stone by Adamsez?

Shaped by Heritage - Refined for Today

With origins in the late 19th century, Adamsez has always been guided by thoughtful design and enduring expertise. Our Stone collection continues this legacy, pairing sculpted form with modern materials to create baths shaped for balance, comfort and lasting quality.

Lifetime Guarantee

Each stone bath is cast from premium composite stone and built for long-term durability. Our lifetime guarantee reflects the strength and reliability of every piece, giving you confidence for years to come.

Sculptural Designs

The Stone by Adamsez collection brings together a focused selection of distinctive forms - from soft curves to stronger architectural lines. Cast to precise proportions, every bath offers warm tactility, generous comfort and a timeless presence in contemporary spaces.

For acrylic baths by Adamsez, explore our dedicated range within the Aqualla brochure - created for practical, everyday luxury.

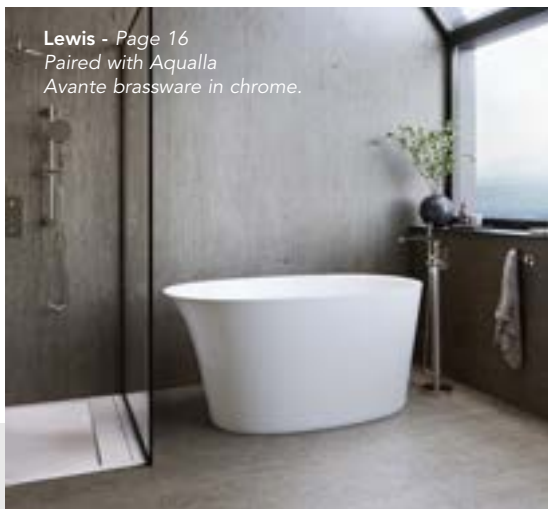

Customisation with AdColour



With AdColour, you can personalise your stone bath with a bespoke outer finish. Choose from a palette of subtle neutrals, deeper tones, or specific colour-matching to create a bath that fits seamlessly with your interior.

See page 46 for more information.

Pair with Aqualla Products

As part of the Aqualla family, our stone baths can be paired effortlessly with Aqualla taps, showers, mirrors and accessories to create a cohesive bathroom design. Explore the full range at aquallabrassware.com or via the Aqualla brochure.



Freestanding Stone Baths

With a heritage stretching back to the late 19th century, Adamsez has long championed the art of pairing purposeful design with enduring craftsmanship. Today, that legacy continues in a collection of sculpted stone baths shaped for balance, comfort and timeless modernity.



AdCast Stone by **ADAMSEZ**[®]

Our Stone Bath collection is crafted using **AdCast**, a premium composite stone that ensures a durable, flawless finish.

Made from the finest materials, these baths are designed to last a lifetime.

Hand-finished by our skilled artisans, each bath is available with bespoke outer finishes to suit any bathroom aesthetic.

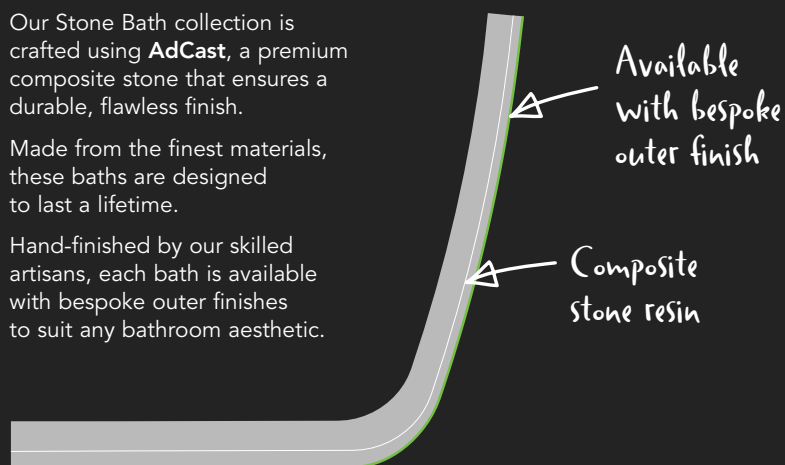

The Stone Bath Collection



Thompson



Harland



Lewis



Clarendon



Geo



Mila



Santo



Lincoln



York



T H O M P S O N

Harland

Where precision meets poise.

Inspired by Belfast's shipbuilding heritage, the HARLAND pairs sculpted form with ergonomic comfort.

Made from composite stone with integrated overflow and clicker waste, it offers generous space and enduring design.



AdColour;
Make Me Yours

Coloured pricing
available on request.

HARLAND
Stone Bath
Code: HAR/157X68

(L) 1570 x (W) 680 x (H) 650mm

Weight: 90 kg
Volume: 210 litres approx.

£2,064.00 Inc. VAT
£1,720.00 Net

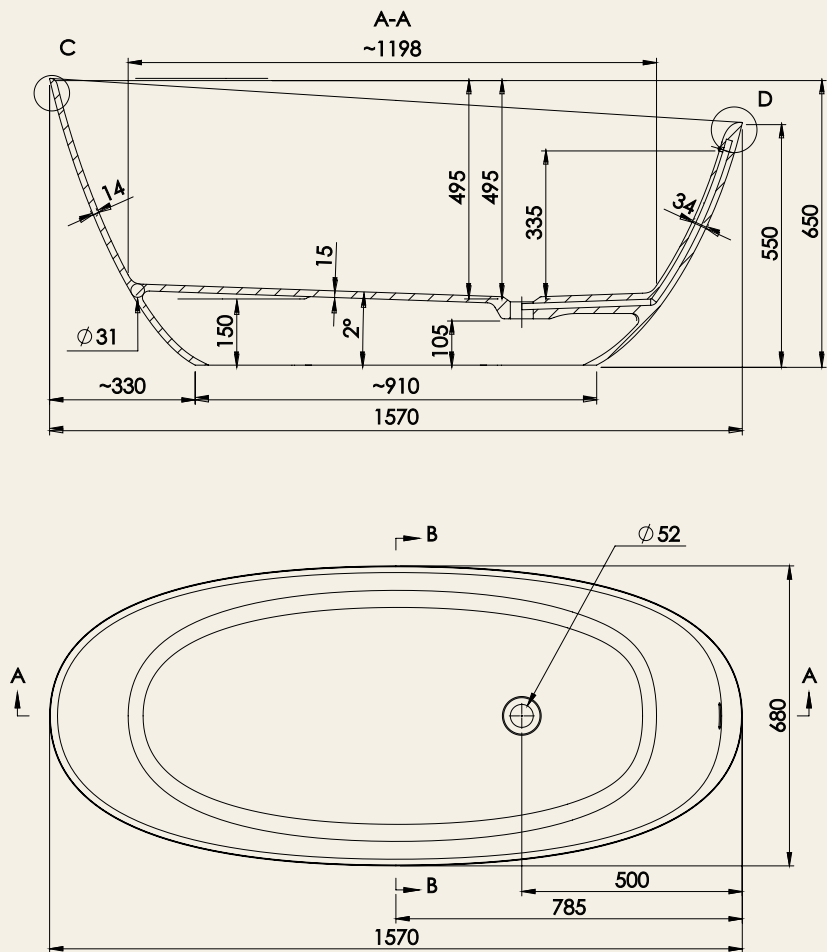

HARLAND pictured with
Aquila Ivy matt black
freestanding bath shower mixer.



Lewis

Soft geometry, quiet confidence.

The LEWIS pairs a compact single-ended footprint with a deep, gently curved interior shaped for calming immersion. Crafted from composite stone with an integrated overflow and clicker waste, it offers warm tactility and enduring comfort for smaller spaces.



AdColour;
Make Me Yours

Coloured pricing
available on request.

LEWIS

Stone Bath

Code: LEW/140X78

(L) 1400 x (W) 780 x (H) 665mm

Weight: 150 kg

Volume: 273 litres approx.

£2,208.00 Inc. VAT

£1,840.00 Net

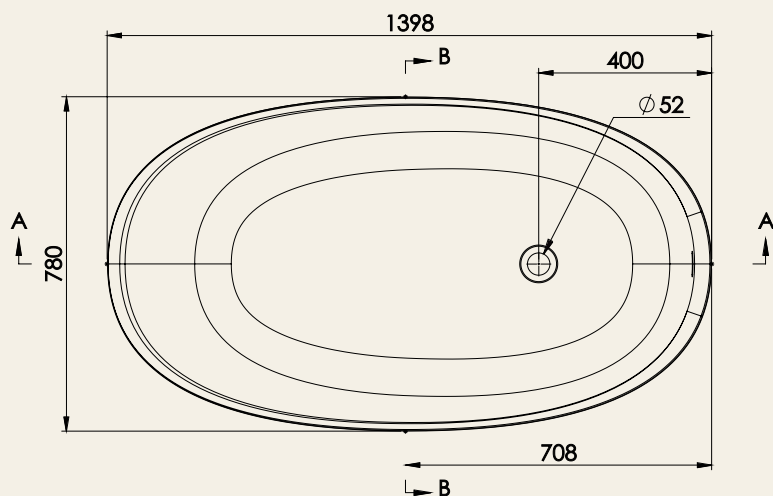
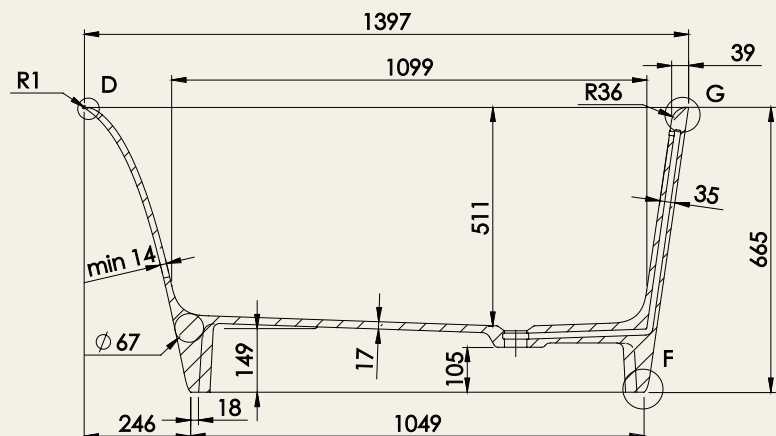

LEWIS pictured with Aqualla Avante brushed brass freestanding bath shower mixer.

PRACTICAL - STYLISH
- SPACIOUS -



L E W I S

Clarendon

Heritage expressed in form.

Inspired by Belfast's maritime craft, the CLARENDON combines a refined double-ended profile with spacious, balanced symmetry. Formed from composite stone using an eco-conscious lightweight design with a clean, overflow-free aesthetic, it offers enduring comfort and a timeless sculptural presence.



AdColour;
Make Me Yours

Coloured pricing
available on request.

CLARENDON

Stone Bath

Code: CLA/160X70

(L) 1600 x (W) 700 x (H) 500mm

Weight: 67 kg

Volume: 265 litres approx.

£1,620.00 Inc. VAT

£1,350.00 Net

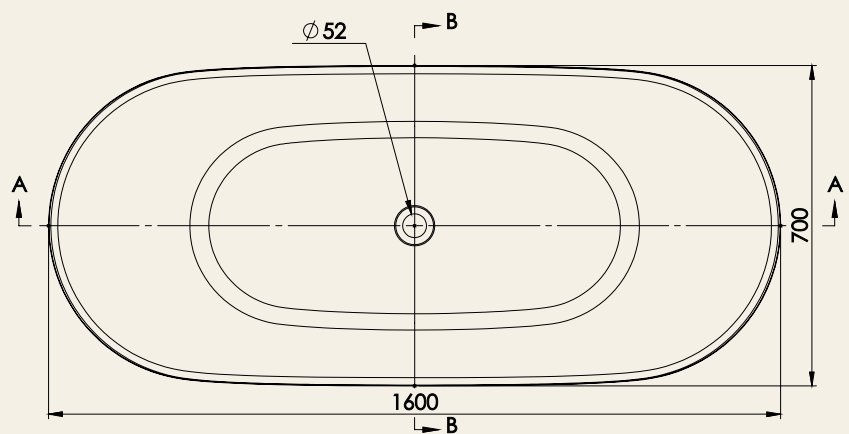
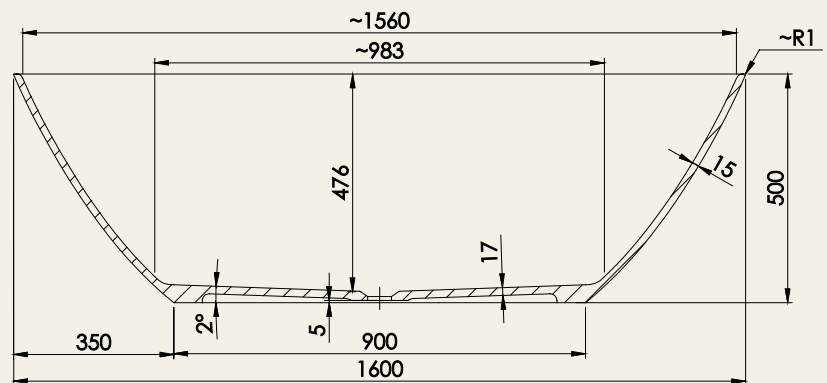

BALANCED - BOLD
- BEAUTIFUL -

CLARENDON pictured with
Aquila Hanna brushed nickel
freestanding bath shower mixer.



C L A R E N D O N

Geo

Sculpted for impact.

The GEO bath features an intricately textured exterior that brings visual interest and a sense of luxury to any bathroom. Available in matt or gloss white, its opulent 3D design provides a striking focal point, while composite stone construction ensures durability and a premium bathing experience.



AdColour;
Make Me Yours

Coloured pricing
available on request.

GEO Matt White Stone Bath

Code: FGEM/WH

(L) 1670 x (W) 832 x (H) 620mm

Weight: 168 kg
Volume: 309 litres approx.

£3,360.00 Inc. VAT
£2,800.00 Net

GEO Gloss White Stone Bath

Code: FGEG/WH

(L) 1670 x (W) 832 x (H) 620mm

Weight: 168 kg
Volume: 309 litres approx.

£3,360.00 Inc. VAT
£2,800.00 Net



GEO Gloss White Bath

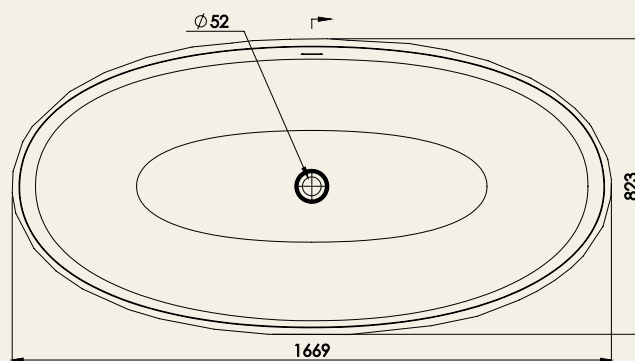
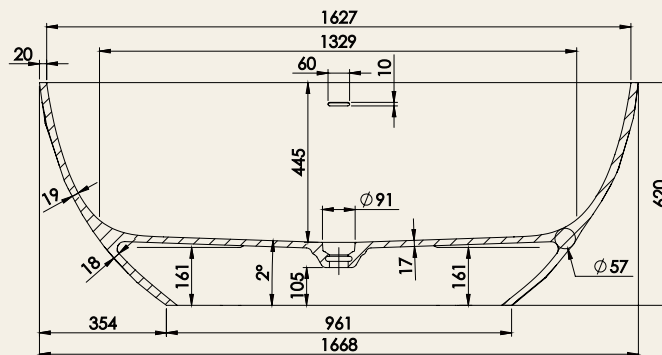

GEO baths pictured with Aqualla Ivy matt black freestanding bath shower mixer.

SCULPTED - STRIKING - INTRICATE



GEO Matt White Bath

G
E
O

Mila

Serenity in simplicity.

The MILA bath offers a sleek, modern design with clean lines and a polished finish, creating a calm and relaxing soak. Crafted from composite stone, it combines minimalist aesthetics with comfort, making it an elegant and luxurious addition to any bathroom.



**AdColour;
Make Me Yours**

Coloured pricing available on request.

MILA Matt Black Stone Bath

Code: FMIM/BL

(L) 1670 x (W) 817 x (H) 620mm

Weight: 138 kg
Volume: 260 litres approx.

£4,797.60 Inc. VAT
£3,998.00 Net

MILA Gloss White Stone Bath

Code: FMIG/WH

(L) 1670 x (W) 817 x (H) 620mm

Weight: 138 kg
Volume: 260 litres approx.

£3,691.20 Inc. VAT
£3,076.00 Net



MILA Matt Black Bath

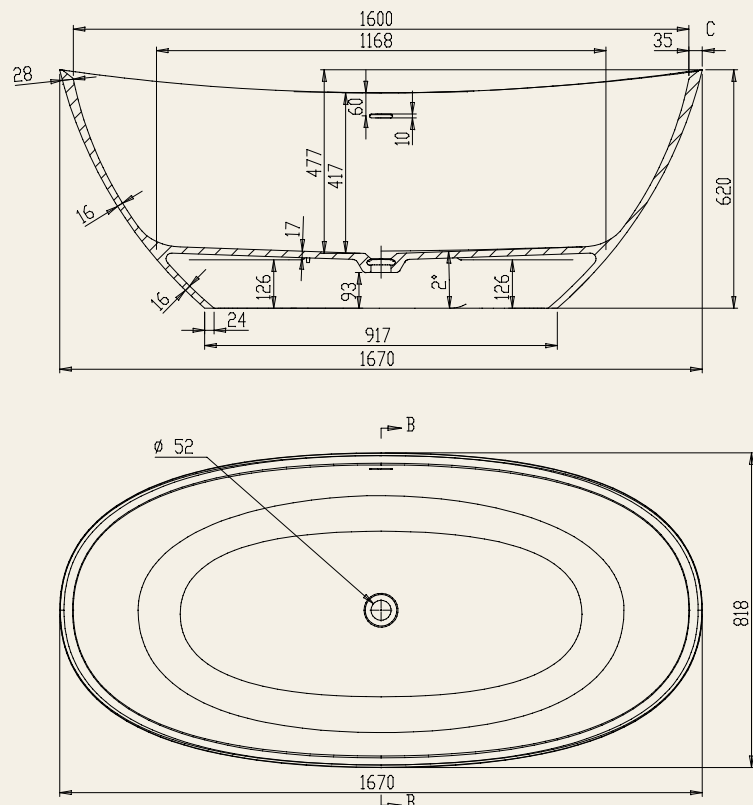

MILA baths pictured with Aqualla Ivy matt black freestanding bath shower mixer.

ARTFUL - PURE - SOPHISTICATED



MILA Gloss White Bath

Santo

Opulence meets versatility.

The SANTO back-to-wall bath offers unparalleled flexibility, allowing taps to be fitted on the shelf, wall, or freestanding. Crafted from composite stone, its luxurious depth and generous dimensions create an indulgent bathing experience, blending refinement with modern practicality.



AdColour;
Make Me Yours

Coloured pricing
available on request.

SANTO Back to Wall Stone Bath

Code: FSAG/WH

(L) 1640 x (W) 830 x (H) 570mm

Weight: 170 kg
Volume: 300 litres approx.

£2,520.00 Inc. VAT
£2,100.00 Net

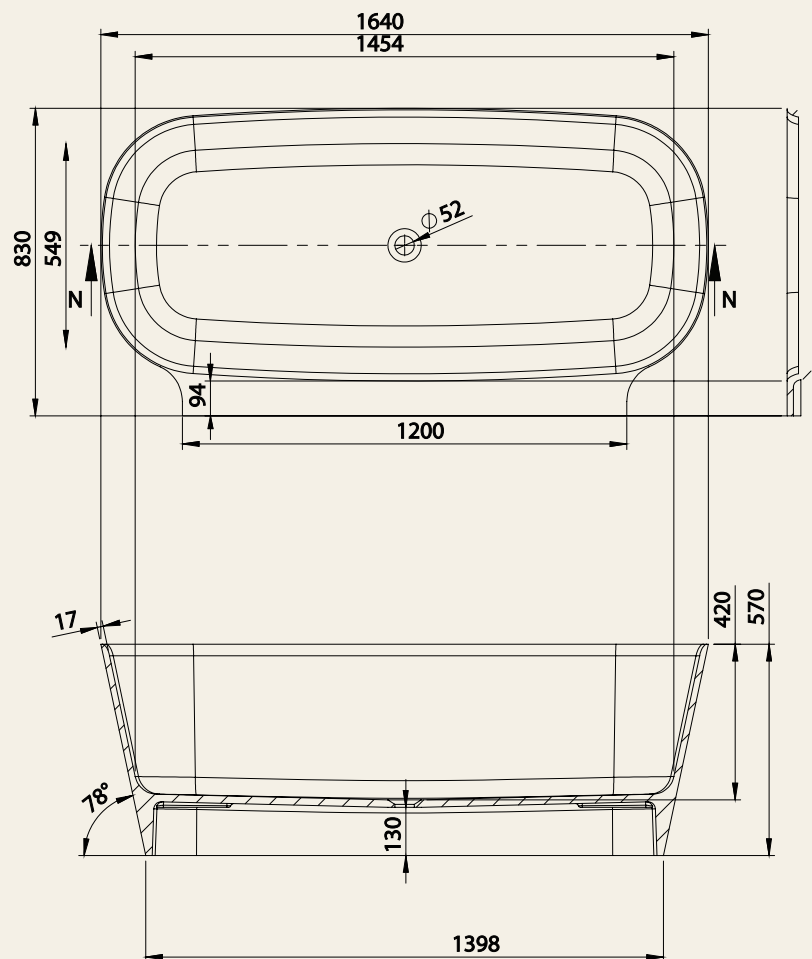

SANTO back to wall bath pictured
with Aqualla Hanna gunmetal grey
freestanding bath shower mixer.

OPULENT
REFINED
VERSATILE



SANTO

Lincoln

Cocooned in luxury.

The LINCOLN's unique single-ended shape offers a long, comfortable soak that perfectly cradles the body. Crafted from composite stone, it delivers depth, spaciousness, and an opulent bathing experience, combining style and sophistication for a truly relaxing retreat.



AdColour;
Make Me Yours

Coloured pricing
available on request.

LINCOLN Stone Bath with Internal Overflow

Code: FLSE/WH

(L) 1693 x (W) 715 x (H) 810mm

Weight: 101 kg

Volume: 210 litres approx.

£2,400.00 Inc. VAT

£2,000.00 Net

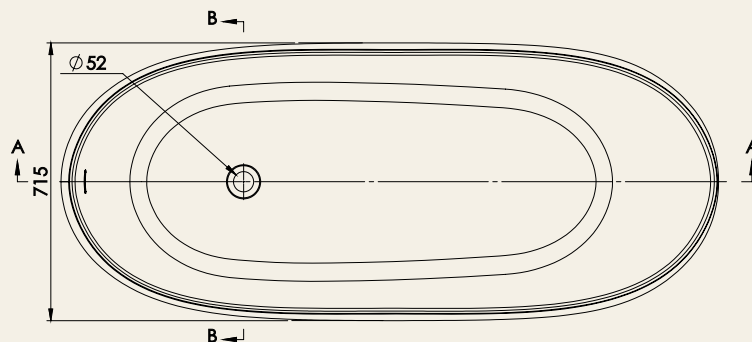
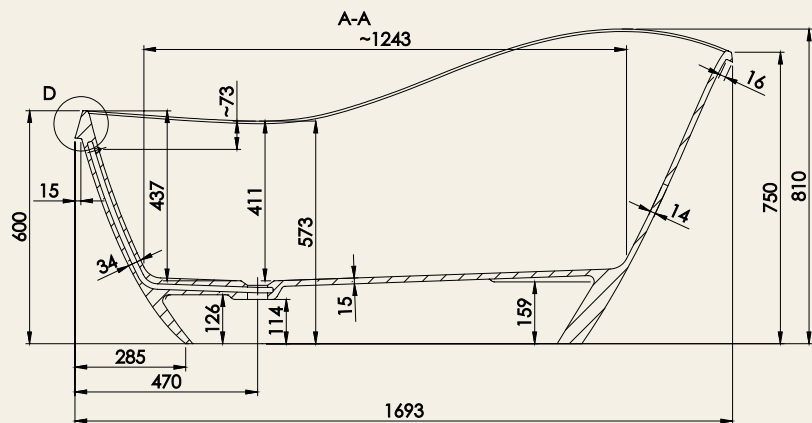

SHAPED - SPACIOUS -
LUXURIOUS

LINCOLN pictured with
Aquila Hannah gunmetal grey
freestanding bath shower mixer.



L I N C O L N

York

Beautifully minimalistic.

The YORK offers the perfect opportunity to unwind at the end of a busy day. This single-ended bath is the epitome of magnificence.

Available in 1605 x 805mm, the YORK bath provides a compact footprint with generous bathing space.



**AdColour;
Make Me Yours**

Coloured pricing
available on request.

YORK

Stone Bath

Code: FYSE/WH

(L) 1605 x (W) 805 x (H) 600mm

Weight: 92 kg

Volume: 360 litres approx.

£2,275.20 Inc. VAT

£1,896.00 Net

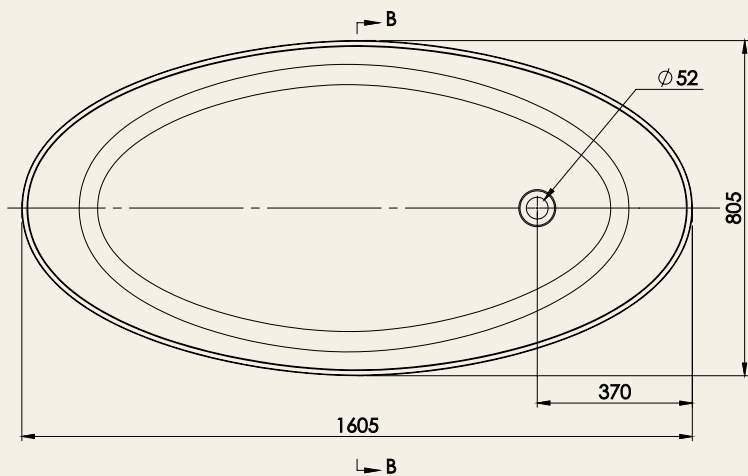
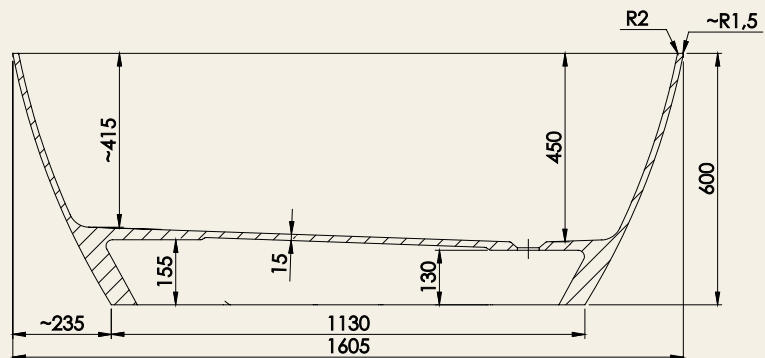

YORK pictured with Aqualla
Kyløe brushed nickel freestanding
bath shower mixer.

CALM - CAPTIVATING -
COMPACT



Y O R K



Olympic II Basin - Page 34

THE
Stone by Adamsez
WASH BASIN COLLECTION

Pair your Bath with a Statement Stone Basin

Our stone basins are crafted from a Mineral Composite structure, combining Dolomite Stone and Resin. This combination imparts unparalleled durability and impact-resistance to Mineral Composite.

With 11 basin designs to complement the shape of our baths and endless bespoke outer finishes, the AdCast Stone Wash Basin collection offers increased personalisation of your Wash Basin.



Plazza Wash Basin. Pictured with Aqualla Kyloe Matt Black Tall Basin Mono Mixer and Fuse Black Round Mirror - See Page 37.



AdColour;
Make Me Yours

Coloured pricing available on request.



Pebble Wash Basin with Aqualla Avante Brushed Brass Tall Basin Mono Mixer - See Page 35.



Mila Gloss White Wash Basin on an AdCast 1210 x 460mm Countertop with Aqualla Ivy Matt Black Tall Basin Mixer and Aqualla Fuse Mirror.

Geo

Available in Matt White & Gloss White



AdColour;
Make Me Yours

Coloured pricing
available on request.

Size: (L) 560 x (W) 370 x (H) 147mm
Weight: 11 kg

GEO
Matt White Basin
Code: GEBM/WH

£406.80 Inc. VAT
£339.00 Net

GEO
Gloss White Basin
Code: GEBG/WH

£406.80 Inc. VAT
£339.00 Net

Comes with a waste cover only (not a complete waste).
Coloured pricing available on request.

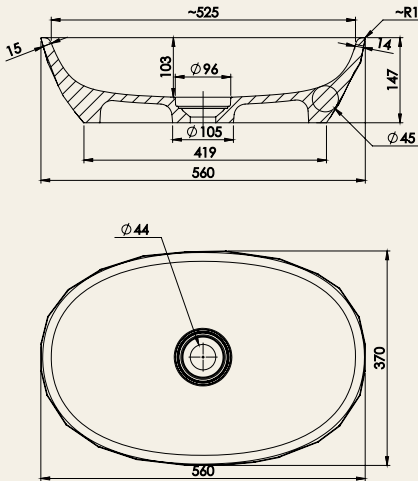

Olympic II

Size: (L) 540 x (W) 300 x (H) 150mm
Weight: 11 kg
Code: OLY/54X30

£452.40 Inc. VAT / £377.00 Net

Comes without a waste.
Coloured pricing available on request.

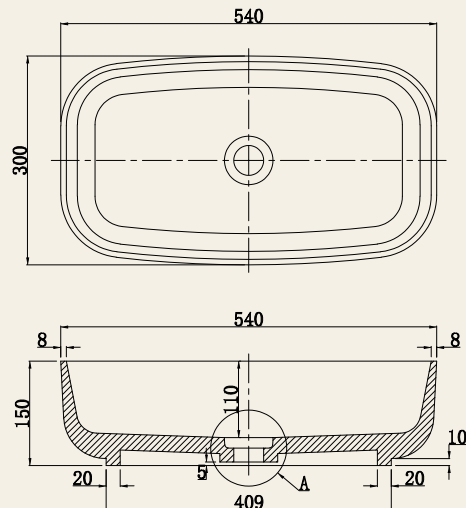

Pebble

Size: (L) 335 x (W) 285 x (H) 102mm
Weight: 3 kg
Code: PEB/33X28

£210.00 Inc. VAT / £175.00 Net

*Comes without a waste.
 Coloured pricing available on request.*

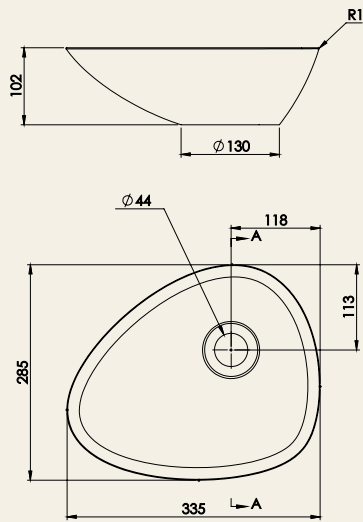

Gem

Size: (L) 420 x (W) 420 x (H) 239mm
Weight: 8 kg
Code: GEM/42X42

£445.20 Inc. VAT / £371.00 Net

*Comes with stone waste.
 Coloured pricing available on request.*

Please note: When selecting your basin, consider the basin's height to ensure optimal installation. This basin is suitable for wall mounted taps only.

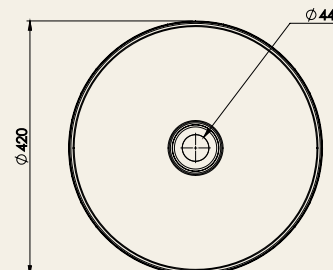
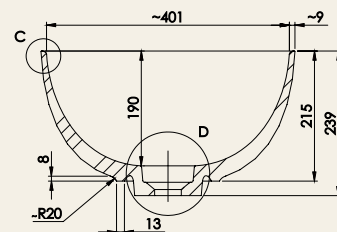

Sonata

Size: (L) 360 x (W) 360 x (H) 150mm

Weight: 7.5 kg

Code: SON/36X36

£396.00 Inc. VAT / £330.00 Net

*Comes without a waste.
Coloured pricing available on request.*

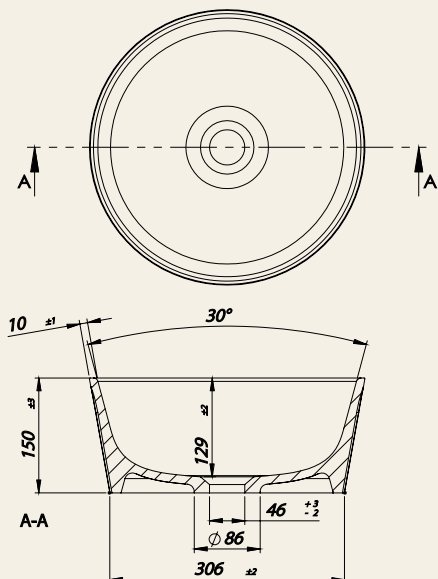

Cara II

Size: (L) 560 x (W) 303 x (H) 150mm

Weight: 12.5 kg

Code: CAR/56X30

£452.40 Inc. VAT / £377.00 Net

*Comes without a waste.
Coloured pricing available on request.*

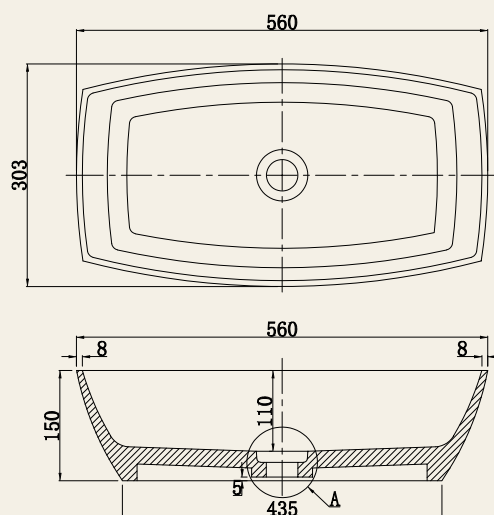

Orb



AdColour;
Make Me Yours

Coloured pricing
available on request.

Size: (L) 420 x (W) 420 x (H) 160mm
Weight: 11 kg
Code: ORB/WH

£270.00 Inc. VAT / £225.00 Net

Comes without a waste.
Coloured pricing available on request.

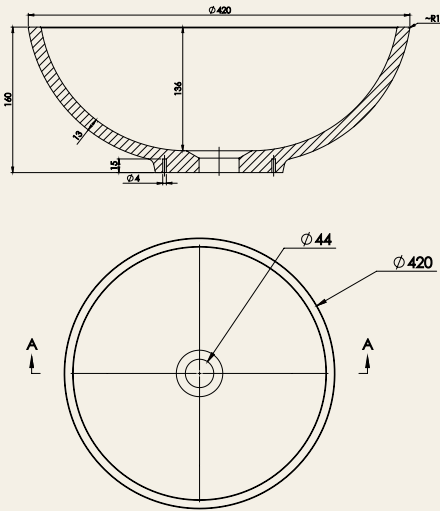

Plazza

Size: (L) 500 x (W) 350 x (H) 124mm
Weight: 6.5 kg
Code: PLZ/WH

£348.00 Inc. VAT / £290.00 Net

Comes without a waste.
Coloured pricing available on request.

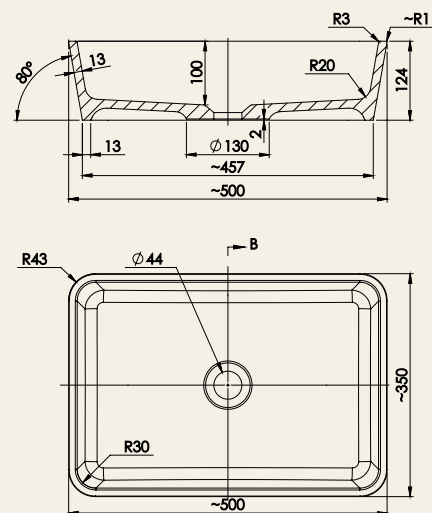

Thompson

Size: (L) 400 x (W) 400 x (H) 180mm

Weight: 8 kg

Code: THO/40X40

£476.40 Inc. VAT / £397.00 Net

*Comes with a waste cover only
(not a complete waste).*

Coloured pricing available on request.

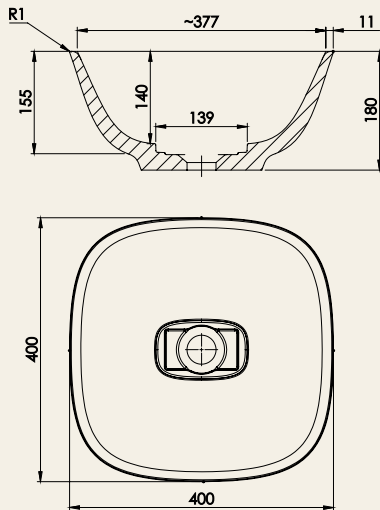

Rochester

Size: (L) 600 x (W) 360 x (H) 150mm

Weight: 12 kg

Code: ROB/WH

£384.00 Inc. VAT / £320.00 Net

Comes without a waste.

Coloured pricing available on request.

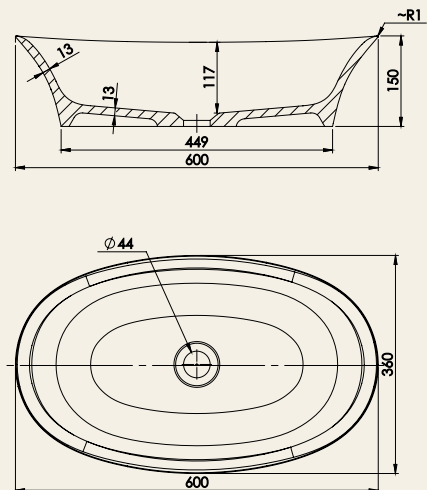

Mila *Available in 2 sizes and in Matt Black & Gloss White*

Size: (L) 600 x (W) 360 x (H) 160mm
Weight: 10 kg

MILA
Matt Black Basin
Code: MI6BM/BL
£496.80 Inc. VAT
 £414.00 Net

MILA
Gloss White Basin
Code: MI6BG/WH
£382.80 Inc. VAT
 £319.00 Net

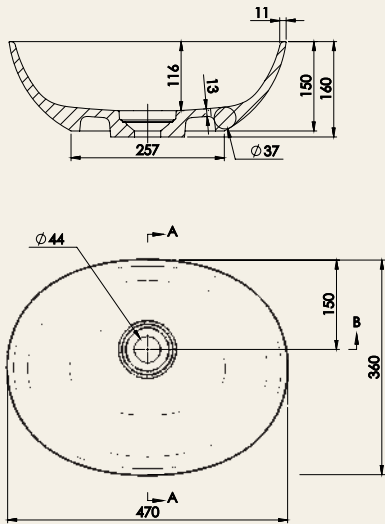

Size: (L) 470 x (W) 360 x (H) 160mm
Weight: 8 kg

MILA
Matt Black Basin
Code: MI4BM/BL
£417.60 Inc. VAT
 £348.00 Net

MILA
Gloss White Basin
Code: MI4BG/WH
£321.60 Inc. VAT
 £268.00 Net

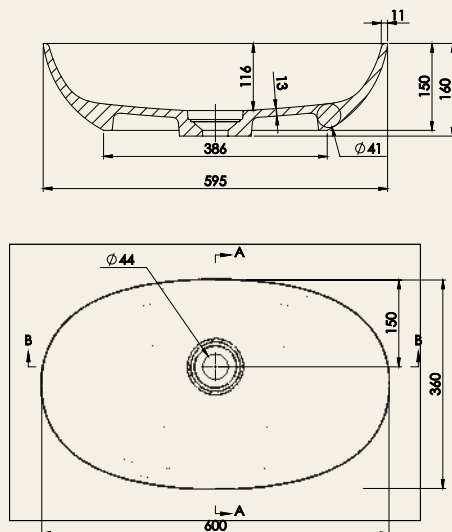

Comes with a waste cover only
 (not a complete waste).
 Coloured pricing available on request.



AdColour;
Make Me Yours

Coloured pricing
 available on request.

AdCast *Countertops*

Made from the same high-quality natural stone as our basins, AdCast Countertops create a cohesive and luxurious look throughout the bathroom.

The stone shelf can also be used to enhance the look of a stone basin and provide additional counter space, making it a perfect addition for those who want to add a touch of luxury aesthetic and functionality to their bathroom.

Mila Gloss White Wash Basin on an AdCast 1210 x 460mm Countertop with Aqualla Hanna Matt Black Wall Mounted Basin Mixer and Aqualla Fuse Mirror.



Please scan the QR Code for technical information on these countertops



AdCast

*610 x 460mm
Countertop*

Colour: Gloss White

Weight: 11kg

Code: CT610/WH

£244.80 Inc. VAT / £204.00 Net

**Bracket Set
for Countertop**

Code: BSCT

£76.80 Inc. VAT / £64.00 Net



AdCast

*810 x 460mm
Countertop*

Colour: Gloss White

Weight: 16kg

Code: CT810/WH

£303.60 Inc. VAT / £253.00 Net

**Bracket Set
for Countertop**

Code: BSCT

£76.80 Inc. VAT / £64.00 Net



AdCast

*1210 x 460mm
Countertop*

Colour: Gloss White

Weight: 20kg

Code: CT1210/WH

£418.80 Inc. VAT / £349.00 Net

**Bracket Set
for Countertop**

Code: BSCT

£76.80 Inc. VAT / £64.00 Net

Optional Extras

Adamsez BATH waste and overflow bath filling options in a variety of finishes can be purchased to match Aqualla Brassware finishes on specific baths as explained in the tables below.

BATHS		OPTIONAL EXTRAS			
Product	Comes Complete With	Bath Waste Unslotted	Bath Waste with EasyClean	Overflow Filler (Round)	Other
Thompson	White Stone Waste	–	–	–	–
Harland	White Waste	–	–	–	–
Lewis	White Waste	–	–	–	–
Clarendon	White Waste	–	–	–	–
Geo	White Stone Waste	–	–	–	–
Mila White	Chrome Waste	–	–	–	–
Mila Black	Black Waste	–	–	–	–
Santo	Waste Not Supplied	•	–	–	W03
Lincoln	Chrome Waste	–	–	–	–
York	Chrome Waste	•	–	–	–



Bath Waste Unslotted

- Brushed Bronze:** BW-BR
£55.20 Inc. VAT / £46.00 Net ●
- Gunmetal Grey:** BW-GG
£55.20 Inc. VAT / £46.00 Net ●
- Brushed Brass:** BW-BB
£55.20 Inc. VAT / £46.00 Net ●
- Brushed Nickel:** BW-BN
£52.80 Inc. VAT / £44.00 Net ●
- Matt Black:** BW-BL
£52.80 Inc. VAT / £44.00 Net ●
- Chrome:** BW-CH
£40.80 Inc. VAT / £34.00 Net ●



Bath Waste with EasyClean

- Brushed Bronze:** BCWEC-BR
£76.80 Inc. VAT / £64.00 Net ●
- Gunmetal Grey:** BCWEC-GG
£76.80 Inc. VAT / £64.00 Net ●
- Brushed Brass:** BCWEC-BB
£76.80 Inc. VAT / £64.00 Net ●
- Brushed Nickel:** BCWEC-BN
£73.20 Inc. VAT / £61.00 Net ●
- Matt Black:** BCWEC-BL
£73.20 Inc. VAT / £61.00 Net ●
- Chrome:** BCWEC
£52.80 Inc. VAT / £44.00 Net ●



Overflow Filler (Round)

- Brushed Bronze:** B-RO-BR
£220.80 Inc. VAT / £184.00 Net ●
- Gunmetal Grey:** B-RO-GG
£220.80 Inc. VAT / £184.00 Net ●
- Brushed Brass:** B-RO-BB
£220.80 Inc. VAT / £184.00 Net ●
- Brushed Nickel:** B-RO-BN
£210.00 Inc. VAT / £175.00 Net ●
- Matt Black:** FU-RO-BL
£210.00 Inc. VAT / £175.00 Net ●
- Chrome:** B-RO
£182.40 Inc. VAT / £152.00 Net ●

Adamsez BASIN waste options in a variety of finishes can be purchased to match Aqualla Brassware finishes on specific basins as explained in the tables below.

STONE BASINS		OPTIONAL EXTRAS		
Product	Comes Complete With	Universal Waste	Basin Waste Unslotted	Other
Thompson	Stone Cover Cap Only	•	•	–
Pebble	Waste Not Supplied	•	•	–
Gem	Stone Waste Supplied	•	•	–
Geo	Stone Cover Cap Only	•	•	–
Olympic II	Waste Not Supplied	•	•	–
Sonata	Waste Not Supplied	•	•	–
Cara II	Waste Not Supplied	•	•	–
Mila	Stone Cover Cap Only	•	•	–
Rochester	Waste Not Supplied	•	•	–
Orb	Waste Not Supplied	•	•	–
Plazza	Waste Not Supplied	•	•	–

Universal Waste



Brushed Bronze: UW-BR
£54.00 Inc. VAT / £45.00 Net



Gunmetal Grey: UW-GG
£54.00 Inc. VAT / £45.00 Net



Brushed Brass: UW-BB
£54.00 Inc. VAT / £45.00 Net



Brushed Nickel: UW-BN
£51.60 Inc. VAT / £43.00 Net



Matt Black: UW-BL
£51.60 Inc. VAT / £43.00 Net



Chrome: UW-CH
£42.00 Inc. VAT / £35.00 Net



Basin Waste Unslotted



Brushed Bronze: CWUS-BR
£37.20 Inc. VAT / £31.00 Net



Brushed Brass: CWUS-BB
£37.20 Inc. VAT / £31.00 Net



Brushed Nickel: CWUS-BN
£34.80 Inc. VAT / £29.00 Net



Matt Black: CWUS-BL
£34.80 Inc. VAT / £29.00 Net



Chrome: CWUS
£30.00 Inc. VAT / £25.00 Net





Thompson Basin - Page 38
Paired with Aqualla Hanna brassware in brushed bronze.



An Exact Shade of Exceptional



AdColour;
Make Me Yours



Lincoln - Page 26
Paired with Aqualla
Hanna brassware in chrome.



York - Page 28
Paired with Aqualla Kyloe
brassware in brushed nickel.



Geo - Page 20
Paired with Aqualla Ivy
brassware in matt black.

**This is only a selection
of colours that we
can add to your bath.**

We can provide a Painting Service and add a colour matched RAL number or any other coded paint to your bath, or alternatively our bespoke Painting Service can colour match, for example a furniture or tile colour to your new bath in a gloss, satin, matt or metallic finish.



For more colours and bespoke finishes please contact us on 028 9081 7631 or alternatively visit us at www.adamsez.com

Our Journey:

Over 140 years of Expertise

Since the 1880s, Adamsez has built a legacy of quality and innovation in the bathroom industry.

Our story reflects key milestones in our pursuit of excellence, evolving while staying true to our founding principles of exceptional design and precision engineering.

1880: Founding of Adamsez
M.J. Adams and S.H. Adams establish Adamsez in Newcastle-upon-Tyne, focusing on sanitary ceramic products.

1950-1960: International Recognition
Adamsez win gold medals at the tenth and sixteenth Triennale di Milano, highlighting their excellence in design and quality.

1980s-1990s: Product Diversification
Moves to Belfast and launches compact, corner, and spa baths with whirlpool systems with colour options.

2020s: Acquisition & Revitalisation
Aqualla, a Northern Ireland based brassware specialist, acquires Adamsez, breathing new life into the brand and announcing significant investment for further innovation and development.

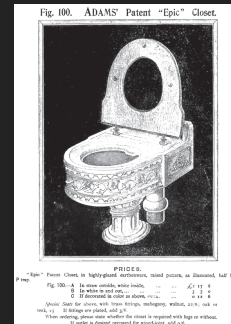

Late 19th to Early 20th Century: Innovation & Expansion
Adamsez gains widespread recognition for producing high-quality, luxurious bathtubs.

1960-1970s: Technological Advancements
Adamsez innovates with new materials and designs in the bath market, staying ahead of trends and contributing to the growth of modern bathroom aesthetics.

2000s: Continued Excellence
Adamsez maintains its reputation for quality and innovation, adapting to modern design trends while preserving its heritage.

The introduction of freestanding baths and stone baths with bespoke colour painting is available.

2021-Present: Continued Growth
Adamsez continues to grow, introducing new collections that combine its rich heritage with modern design and innovative features.

Aqualla and Adamsez are part of the FM Mattsson Mora Group which brings together several of Europe's, leading bathroom brands.

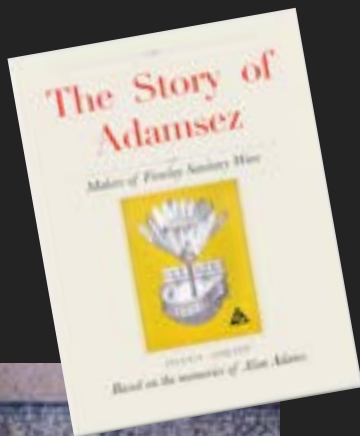



Lewis - Page 16
Paired with Aqualla Avante brassware in brushed brass.



AQUALLA®



Complete your bathroom with **Taps, Showers, Acrylic Baths, Radiators, Mirrors** and **Accessories** all of which work seamlessly with **Adamsez** products.

Tailor made with you in mind: Explore, Engage, Evolve.

- **Easy to Navigate Product Pages:** Find codes, pricing, and comprehensive variant details.
- **Convenient Search Functionality:** Search by colour, code, or description.
- **Inspirational Image Galleries:** Be inspired with aspirational imagery, leading you directly to featured products.
- **Wishlist Feature:** Easily select, save, and share your favourites.
- **Retailer and Customer Service Hubs:** Connect with us directly for unparalleled support.



But that's not all; there's so much more to explore, including our Lifestyle and Kitchen Collection brochures - Discover The Aqualla Difference Now.



Telephone: +44 (0) 28 9182 8000
aquallabrassware.com

Our Sustainability Journey

We are making small steps to meaningful change by actively seeking ways to reduce our carbon footprint.

A THOUGHTFUL APPROACH TO SUSTAINABILITY

As part of the FM Mattsson Group, Aqualla and Adamsez share a commitment to responsible manufacturing and long-term sustainability. While Aqualla delivers water-efficient brassware that helps reduce everyday consumption, our stone baths contribute through low-impact materials, reduced waste and cleaner production.

POWERED BY 100% GREEN ENERGY

Every Adamsez stone bath is produced using 100% renewable energy, significantly reducing its manufacturing footprint. This clean-energy process reflects our belief in combining modern precision with more conscious production methods.

DESIGNED TO LAST

Composite stone offers outstanding durability, helping reduce waste over the long term. With a repairable surface, recyclable materials and timeless design integrity, the Stone Collection is created to last - and to be chosen only once.

PART OF A GROUP-LEVEL SUSTAINABILITY JOURNEY

FM Mattsson Group holds a Bronze EcoVadis Sustainability Rating, placing us among the top 35% of companies assessed globally. This recognition reflects shared progress across environment, energy use, ethics and responsible procurement - progress carried across every brand, including Aqualla and Adamsez.

Let's work together to make things better.



ADAMSEZ



AQUALLA

Scan the QR Code to download a PDF version of this brochure.

Due to the process of continuous development we reserve the right to alter specification without notice.

Lifetime Guarantee

Adamsez baths, basins and countertops are guaranteed against manufacturing defects for the lifetime of the first domestic purchaser.

The product will be replaced or refunded at the manufacturer's discretion.

No other loss is guaranteed.

This guarantee applies only to domestic purchases in the UK and Republic of Ireland and is non-transferable.

Proof of purchase will be required.

Errors and Omissions

We reserve the right to amend prices due to errors or omissions without notice.





Telephone +44 (0) 28 9081 7631
Email info@adamsez.com

www.adamsez.com

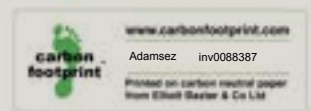

Scan the QR Code
to download a PDF
version of this brochure

For Internal
Use Only

Edition 11.0
January 2026 / Sterling

